

**NAVSTAR GPS PHASE III  
INTERFACE CONTROL DOCUMENT**

**ICD-GPS-060**

**GPS USER EQUIPMENT —  
PRECISE TIME AND TIME INTERVAL  
(PTTI) INTERFACE**

**REVISION A**

**02 JUNE 1986**

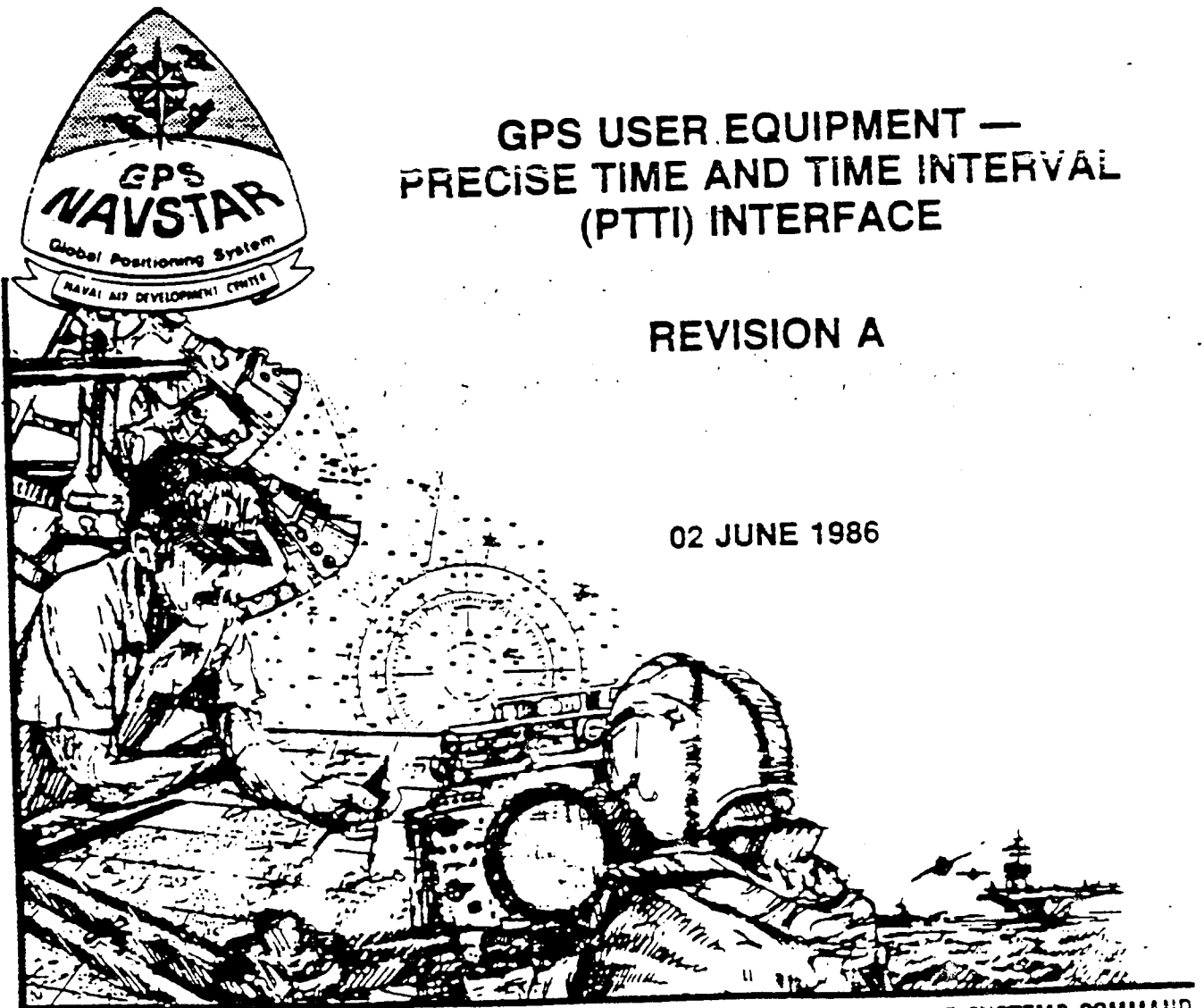

**PREPARED JOINTLY FOR SPACE DIVISION (AFSC) AND SPACE AND NAVAL WARFARE SYSTEMS COMMAND**

APPLICATION				REVISIONS			
NEXT ASSY	USED ON	LYR	DESCRIPTION	DATE	APPROVED		

APPROVALS		
ORGANIZATION	AUTHORIZED SIGNATURE	DATE
GPS JPO (SD/YE)	Dwight D. Green	25 Jul 86
GPS JPO (SD/YEF)	Louis B. Gaines	24 Jul 86
GPS JPO (SD/YES)	[Signature]	7/22/86
GPS JPO (SD/YEU)	[Signature]	22 July 86
GPS JPO (SD/YEA)	[Signature]	22 July 86
GPS JPO (SD/YEI)	[Signature] for [Signature] Lt Col	23 Jul 86
GPS JPO (SD/YE/DOI)	[Signature]	24 Jul 86

FOR AGREEMENT		
ORGANIZATION	SIGNATURE	DATE
Collins Gov't Avionics Div.	[Signature]	18 Jul 86
NAVAIRDEVCON INADC-4093	Charles R. Fabeloth	6/23/86

## INTERFACE CONTROL DOCUMENT

\* - Blank

REV SHEET																												
REV SHEET																												
REV SHEET	A	A	A	A	A	A	A	A	A	A	A	A	A	A	A	A	A	A	A	A	A	A	A	A	A	A	A	A
SHEET	23	24	25	26	27	28	29	30	31	32*	A1	A2*	A3	A4	A5	A6	A7	A8*										
REV STATUS OF SHEETS	REV	A	A	A	A	A	A	A	A	A	A	A	A	A	A	A	A	A	A	A	A	A	A	A	A	A	A	
	SHEET	1	2*	3	4*	5	6	7	8*	9	10	11	12	13	14	15	16	17	18	19	20	21	22					

UNLESS OTHERWISE SPECIFIED, DIMENSIONS ARE IN INTERNATIONAL UNITS TOLERANCES ON: FRACTIONS DECIMALS ANGLES	CONTRACT NO.	GPS USER EQUIPMENT--PRECISE TIME AND TIME INTERVAL (PTTI) INTERFACE	
	DATE 02 JUNE 1986		
	PREPARED		
	CHECKED		
ENGINEER		S.22 CODE IDENT NO	DRAWING NO
		A 80206	ICD-GPS-060
	SCALE	REV	SHEET
		A	1/2



NAVSTAR GPS PHASE III  
INTERFACE CONTROL DOCUMENT

GPS USER EQUIPMENT  
PRECISE TIME AND TIME INTERVAL  
(PTTI) INTERFACE  
DRAWING NO.: ICD-GPS-060

2 June 1986

SIZE	CODE IDENT NO.	DRAWING NO.	
A	80206	ICD-GPS-060	
SCALE	REV	SHEET	
	A	3	4

↓

**TABLE OF CONTENTS**

<u>Paragraph</u>	<u>Page</u>
1.0 PURPOSE .....	9
1.1 Agencies/Contractors .....	9
1.1.1 GPS Joint Program Office .....	9
1.1.2 Air Force Development Activity .....	9
1.1.3 Navy Development Activity .....	9
1.1.4 Interface Control Agency .....	9
2.0 OVERVIEW .....	10
2.1 GPS Time Standard .....	10
2.2 U.S. Naval Observatory .....	10
2.3 Scope .....	12
3.0 APPLICABLE DOCUMENTS .....	12
3.1 Definition .....	14
4.0 DESCRIPTION .....	16
4.1 GPS User Equipment .....	16
4.2 General Characteristics .....	17
4.3 Signal Inputs To PTTI Port .....	19
4.3.1 Time Rollover Pulse (1 PPS) .....	19
4.3.1.1 Functional Description .....	19
4.3.1.2 Signal Characteristics .....	19
4.3.1.3 Electrical Characteristics .....	19
4.3.2 BCD Time Code .....	19
4.3.2.1 Functional Description .....	19
4.3.2.2 Signal Characteristics .....	19
4.3.2.3 Electrical Characteristics .....	19
4.3.2.4 Deviations From The 40 Bit Time Code .....	22
4.3.3 Timing Fault Discrete .....	22
4.3.3.1 Functional Description .....	22
4.3.3.2 Signal Characteristics .....	22
4.3.3.3. Electrical Characteristics .....	22
4.3.4 Configuration Inputs .....	22
4.4 Signal Outputs From The PTTI Port .....	22
4.4.1 Time Rollover Pulse (1 PPS) .....	22
4.4.1.1 Functional Description .....	22
4.4.1.2 Signal Characteristics .....	23
4.4.1.3 Electrical Characteristics .....	23
4.4.2 Time Synchronizing Signal (1 PPS) .....	23
4.4.2.1 Functional Description .....	23

SIZE	CODE IDENT NO.	DRAWING NO.
A	80206	ICD-GPS-060
SCALE	REV	SHEET
	A	5

↑

↓

TABLE OF CONTENTS (CON'T)

<u>Paragraph</u>	<u>Page</u>
4.4.2.2 Signal Characteristics .....	23
4.4.2.3 Electrical Characteristics .....	23
4.4.3 BCD Time Code .....	23
4.4.3.1 Functional Description .....	23
4.4.3.2 Signal Characteristics .....	23
4.4.3.3 Electrical Characteristics .....	23
4.4.4 Timing Fault Discrete .....	25
4.4.4.1 Functional Description .....	25
4.4.4.2 Signal Characteristics .....	25
4.4.4.3 Electrical Characteristics .....	25
4.4.5 HAVE QUICK Interface .....	25
4.4.5.1 Functional Description .....	25
4.4.5.2 Signal Characteristics .....	25
4.4.5.3 Electrical Characteristics .....	27
4.4.5.4 Message Format .....	27
4.4.5.5 Modified Hamming Code .....	27
4.5 Short Circuit Protection .....	27
4.6 Time Figure of Merit .....	27
4.7 Control and Display PTTI Functions .....	31
4.7.1 Functional Description .....	31
4.7.2 Time Standard Error Display .....	31
4.7.2.1 Functional Description .....	31
4.7.2.2 Display Characteristics .....	31
4.8 Safety .....	31
 APPENDIX A	
A1.0 PTTI APPLICATIONS .....	A-3
A.1.1 Use with UE 1553A/B I/O Port .....	A-3
A.1.2 Use with Cesium Standard .....	A-3
A.1.3 Use with Frequency Standard .....	A-3
A.1.4 Use with Frequency Hopping Radio Systems .....	A-3

SIZE	CODE IDENT NO.	DRAWING NO.
A	80206	ICD-GPS-060
SCALE	REV	SHEET
	A	6

↑

↓

LIST OF FIGURES

Figure	Title	Page
1.	Pseudo-Range .....	11
2.	Determination of User Position and Time Offset (Two Dimensional Case) .....	11
3.	The Inter-Relationship of the Different Methods of Measuring and Defining Time .....	15
4.	GPS-UE PTTI Interfaces .....	18
5.	Input Time Rollover Pulse (1 PPS) Signal Characteristics .....	20
6.	Signal Characteristics of BCD Time Code .....	21
7.	Output Time Rollover Pulse (1 PPS) and Time Synchronizing Signal (1 PPM) Signal Characteristics .....	24
8.	HAVE QUICK TOD Output Format and Timing.....	26
9.	HAVE QUICK Message Format .....	28
10.	Modified Hamming Code .....	29
11.	Time Figure of Merit Definition .....	30
A-1	Use of PTTI SRU and MIL-1553 Interface to Transmit Precise Time.....	A-4
A-2	GPS UE (Air or Sea Set) PTTI Interface with Exter- nal Cesium Standards .....	A-5
A-3	GPS-UE (Air or Sea Set) PTTI Interface with Exter- nal Frequency Standard .....	A-6
A-4	GPS-UE (Air or Sea Set) HAVE QUICK Applications...	A-7

SIZE	CODE IDENT-NO.	DRAWING NO.
A	80206	ICD-GPS-060
SCALE	REV	SHEET
	A	7/8

↑

1.0 PURPOSE

This document describes the Global Positioning System (GPS) production version (Phase III), Precise Time and Time Interval (PTTI) interface port.

1.1 Agencies and Contractors. This document is controlled in accordance with the provisions of the GPS Interface Control Working Group (ICWG) charter by the following agencies.

1.1.1 GPS Joint Program Office. The GPS JPO is responsible for the development of the GPS system.

Headquarters, Space Division AFSC  
Code SD/YEUE  
P.O Box 92960 Worldway Postal Center  
Los Angeles, CA 90009-2960  
Phone (213) 643-1644  
AUTOVON 833-1644  
TELEFAX (213) 643-0720

1.1.2 Air Force Development Activity. The Space Division, AFSC is responsible for the development, configuration and life cycle support of the GPS UE for the Air Force.

Space Division AFSC  
Code SD/YEUF  
P.O. Box 92960 Worldway Postal Center  
Los Angeles, CA 90009-2960  
Phone (213) 643-1206  
AUTOVON 833-1206  
TELEFAX (213) 643-0720

1.1.3 Navy Development Activity. The Space and Naval Warfare Systems Command is responsible for the development, configuration management and life cycle support of the GPS UE for the Navy.

Space and Naval Warfare Systems Command  
Code PDW-106-2E  
Washington, DC 20363-5100  
Phone (202) 692-5213  
AUTOVON 222-5213  
TELEFAX (202) 692-4758

1.1.4 Interface Control Agency. The Naval Air Development Center is responsible for maintaining the technical validity of this ICD.

SIZE	CODE IDENT NO.	DRAWING NO.	
A	80206	ICD-GPS-060	
SCALE	REV	A	SHEET
			9

Naval Air Development Center  
Code 4093  
Warminster, Pa 18974-5000  
Phone (215) 441-1200  
AUTOVON 441-1200  
TELEFAX (215) 441-1998

## 2.0 OVERVIEW

**2.1 GPS Time Standard.** In terms of navigational accuracy, one nanosecond of time error is equivalent to approximately 0.3 meters (0.984 ft) of range error, so that precision timing and frequency control are essential to the GPS system. All system timing requirements are synchronized with GPS system time, which is maintained by the Master Control Station (MCS) through the use of a set of highly stable cesium clocks. Precision timing is maintained in the space vehicles (SV) by the use of a highly stable atomic clock in each vehicle with a known or predictable offset from GPS system time. The MCS monitors the SV time standards daily, with reference to GPS system time, and generates clock correction parameters for transmission to the SV's where they are retransmitted to users with the navigational signals and used to determine the precise magnitude of the clock offsets. Figures 1 and 2 illustrate the clock offset.

GPS system time necessarily differs from Coordinated Universal Time (UTC), which must be adjusted for leap seconds at periodic intervals. The difference between GPS system time and UTC is transmitted by the space vehicles.

The space vehicle clock frequency is nominally 10.23 MHz, which is offset slightly to a center frequency of 10.22999999545 MHz to allow for relativity effects. Its maximum allowable uncertainty is one part in  $10E12$  per day. The MCS has the capability of adjusting both the clock time phase, and frequency, if required. The phase can be adjusted to a resolution of one chip (97.75 nanoseconds). The frequency can be set in steps no smaller than  $4 \times 10E-12$  delta  $f/f$  over a range of  $\pm 2$  parts in  $10E9$  around the center frequency. Upload of clock correction parameters into the space vehicles and adjustment of the clocks is accomplished by uplink commands.

All frequencies in the space vehicle are derived from, and synchronized with, integrals of the basic 10.23 MHz frequency standard.

**2.2 U.S. Naval Observatory.** The mission of USNO is to provide astronomical and time data, as well as to insure

SIZE	CODE IDENT NO.	DRAWING NO.	
A	80206	ICD-GPS-060	
SCALE	REV	SHEET	10
	A		



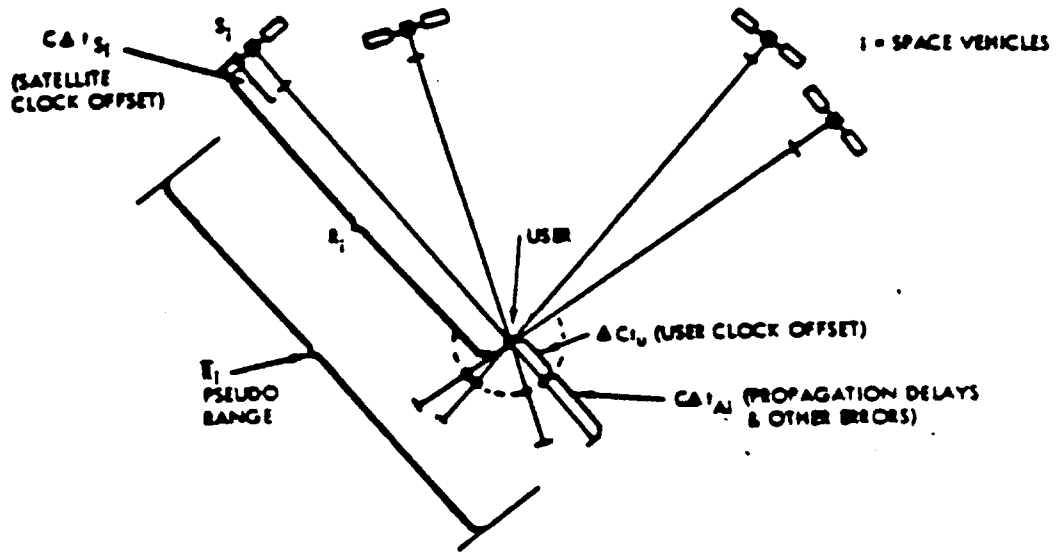

FIGURE 1 PSEUDO-RANGE

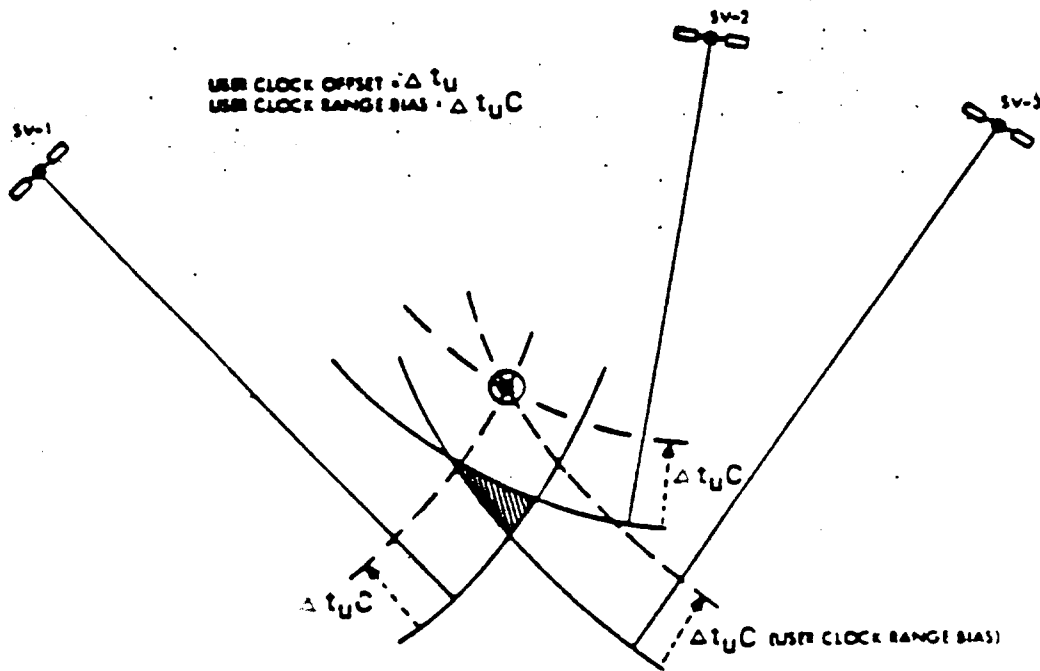

FIGURE 2 DETERMINATION OF USER POSITION AND TIME OFFSET (TWO DIMENSIONAL CASE)

SIZE	CODE IDENT NO.	DRAWING NO.
A	80206	ICD-GPS-060
SCALE	REV	SHEET
		11

uniformity in PTTI operations. It maintains U.S. standards in conjunction with the National Bureau of Standards as well as providing international coordination. This responsibility includes maintenance and dissemination of the U.S. version of UTC and of earth orientation data. In support of this, it also monitors the GPS dissemination of UTC estimates. These functions are performed by the Time Service Division, located in Washington, D.C.

2.3 Scope. This document defines the fundamental electrical, functional, electromagnetic compatibility, and data base requirements that must be met by the GPS UE's Military Standard PTTI Interface for use in DOD applications. These requirements have been formulated to meet the specifications of each of the armed services' existing and anticipated PTTI implementations (TACAMO, EJS, SSN, etc.) as outlined in the NAVELEX Precise Time and Time Interval Requirements Analysis of 1 Sep 1982 and other applicable documents.

### 3.0 APPLICABLE DOCUMENTS

The detailed requirements set forth in this specification were formulated using the following listed documents as references. Clearly, these documents treat common areas differently, and in fact, contain overlapping and conflicting requirements. Whenever possible, conflicts were resolved by citing the most stringent criteria as the applicable design requirement. In those cases where it is impossible to satisfy different sets of criteria using a worst-case approach, both sets of criteria were included as design requirements in an "either/or" fashion.

CP-RCVR-3010  
8 Nov 1985

Computer Program Development  
Specification for the GPS  
Receiver (RCVR 3A) CPCI of  
the User Segment User Equipment  
NAVSTAR Global Positioning  
System

CP-RCVR-3011  
8 Nov 1985

Computer Program Development  
Specification for the GPS  
(RCVR 3S) CPCI of the User  
Segment User Equipment NAVSTAR  
Global Positioning System

CP-AD0100A (Secret Doc)  
31 JUL 1981

Prime Item Fabrication  
Specification for HAVE QUICK  
Task 01, (u) with SCNS 1-7

SIZE	CODE IDENT NO.	DRAWING NO.	
A	80206	ICD-GPS-060	
SCALE	REV	SHEET	
	A	12	

CP-AD0100B (Secret Doc)  
27 FEB 1981

Prime Item Development Specification for HAVE QUICK, Task 01, (u) with SCNS 1-8

DOD-STD-1399 (Navy)  
Section 441  
1 Jun 1982

Interface Standard for Shipboard Systems, Precise Time and Time Interval

ICD-GPS-059  
30 Nov 1985

GPS User Equipment, MIL-STD-1553 Multiplex Bus Interface.

ICD-GPS-202, Draft,

NAVSTAR GPS Control Segment U.S. Naval Observatory Time Transfer Interfaces.

MIL-E-16400G  
December 1974

Electronic, Interior Communication and Navigation Equipment, General Specification for Naval Ship and Shore

MIL-F-28811 (EC)  
17 March 1975

Frequency Standard, Cesium Beam Tube Military Specification

MIL-STD-188-100  
15 November 1972

Common Long Haul and Tactical Communication Systems Technical Standards

MIL-STD-454E  
August 1976

Standard General Requirement for Electronic Equipment

MIL-STD-461A  
May 1970  
Notices 1 and 3

Electromagnetic Interference Characteristics, Requirements for Equipment

MIL-STD-462  
MAY 1970

Electromagnetic Interference Characteristic, Measurement of

MIL-STD-1399A

Interface Standard for Shipboard Systems.

MIL-STD-6051D  
JUL 1968

Electromagnetic Compatibility Requirements, Systems,

NAVAIR-594/SMS  
14 SEP 1983

Time Accuracy Requirement for NAVSTAR GPS.

NAVELEX  
1 SEP 1982

Precise Time and Time Interval Requirements Analysis

SIZE	CODE IDENT NO.	DRAWING NO.
A	80206	ICD-GPS-060
SCALE	REV	SHEET
	A	13

NAVELEX INT 2900.1  
9 July 1980

Precise Time and Time Interval  
(PTTI); Implementation of

NAVELEX NRL  
1 JAN 1983

The U.S. Navy's Standardized  
PTTI Platform Distr. Sys (PDS).

SS-GPS-300B  
3 March 1980

System Specification for the  
NAVSTAR Global Positioning  
System

### 3.1 Definition

Time: signifies epoch, that is, the designation of an instant on a selected time scale, either astronomical or atomic. It is used in the sense of time of day. See Figure 3 for the interrelationship of different methods of measuring and defining time.

Time Interval: indicates the duration of time without reference to when the time interval begins and ends. Time interval is usually given in units of seconds.

Standard: The reference value of time and time interval against which other values of time are measured. These standards are determined by astronomical observation and by the operation of atomic clocks. They are disseminated by transport of clocks, radio transmissions, and by other means.

Frequency Stability: A measure of the variation of the frequency of an oscillator from its mean frequency over a specified period of time.

Frequency Accuracy: The degree to which an oscillator frequency corresponds to that of an accepted definition. In practice, this involves comparison with some generally accepted physical embodiment of this definition such as the NBS Frequency Standard.

Frequency Reproducibility: The degree to which an oscillator will produce the same frequency from one occasion to another, after proper alignment. This does not include calibration.

Settability: The degree to which the frequency of an oscillator may be adjusted to correspond with a reference. This may also be termed calibration.

Time Synchronization: The ability to make a specific pulse of a local time scale occur within predetermined limits of a specific pulse from a selected disseminated time scale.

SIZE	CODE IDENT NO.	DRAWING NO.
A	80206	ICD-GPS-060
SCALE	REV	SHEET
	A	14

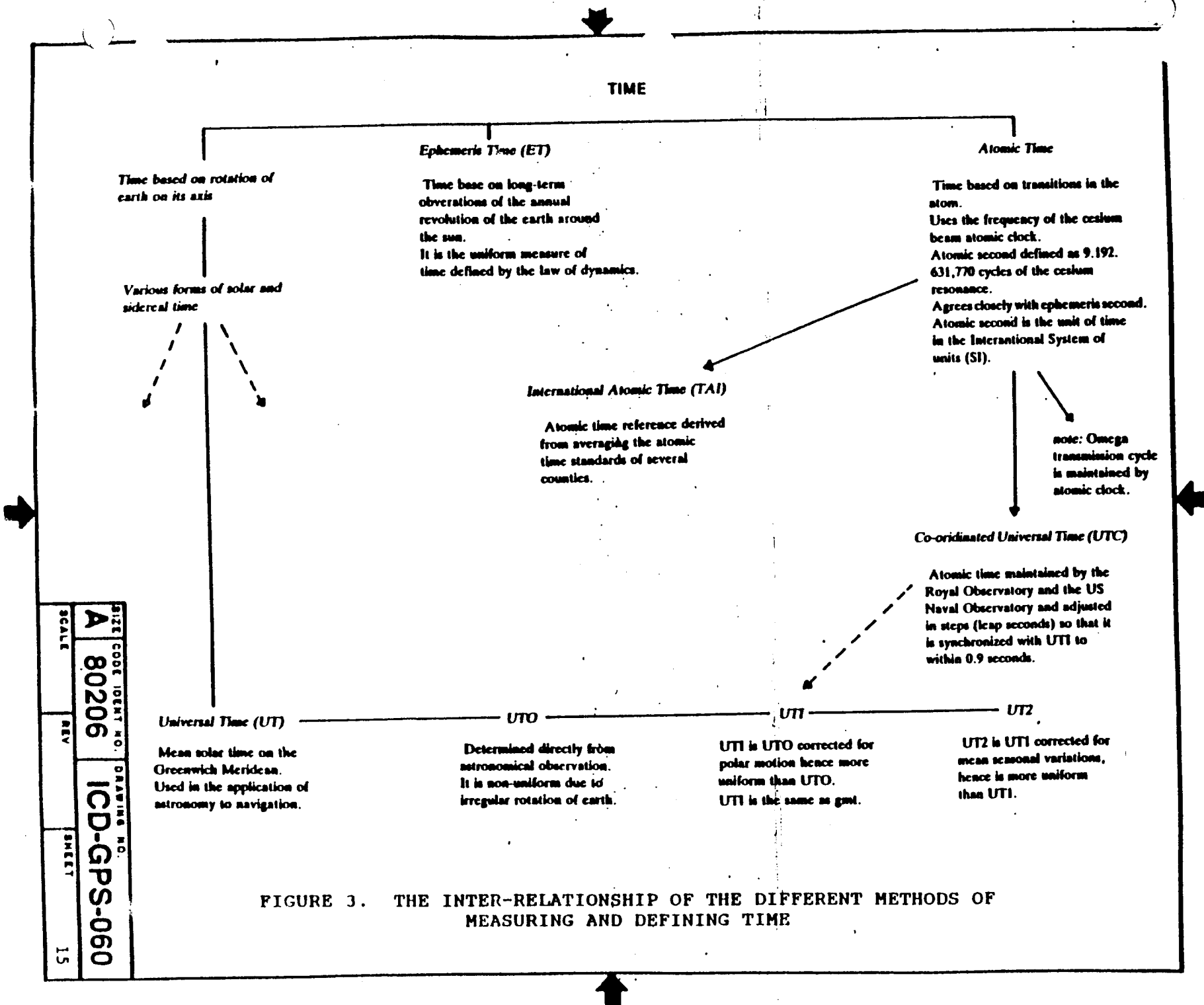

FIGURE 3. THE INTER-RELATIONSHIP OF THE DIFFERENT METHODS OF MEASURING AND DEFINING TIME

SIZE CODE IDENT NO. DRAWING NO. SHEET

A 80206 ICD-GPS-060

SCALE REV SHEET

15

That is, to cause the local scale to be "on time" with respect to the disseminated time scale.

Coordinated Universal Time (UTC): An internationally agreed upon time scale which has the same rate as Atomic Time. UTC is corrected by step adjustments of exactly one second, as needed to remain within 0.9 seconds of Astronomical Time (UT1). The "Bureau International de L'Heure" (BIH) determines when step adjustments are needed. This is the universal time used by DOD and other precise time users.

Atomic Time: A Time scale based on the hyperfine resonance of Cesium 133.

Atomic Second: Precisely, 9,192,631,770 cycles of the cesium resonance.

GPS Time: GPS time is the basic time which the entire system (Control-Space-User) utilizes for its time delay ranging techniques. It is the free running time kept by the Control Segment based upon one of the Monitor Station Cesium Clocks. It is generally considered in units of GPS week number and seconds-of-week.

Satellite Time: Each satellite broadcasts its approximation of GPS time. This approximation is known as satellite time. It consists of the P or C/A code state (Z count) and the satellite clock correction terms in the 50 BPS data stream. Each satellite's time is approximately (within the SS-GPS-300 error budget) equal to GPS time.

UE Clock Time. Each UE currently keeps an internal clock of high precision. This clock is not synchronized to an external time source (in general) currently, but is used for all UE set hardware/software timing functions.

Note: All further references to time are in Coordinated Universal Time (UTC).

#### 4.0 DESCRIPTION

4.1 GPS User Equipment. The various models of military GPS User Equipment are comprised of several integral components, each of which will be designed to satisfy integration requirements for a variety of platforms. These common components, such as the Receiver and Antenna, are referred to as Line Replaceable Units (LRU) which, in turn, are composed of a set of common hardware replaceable modules and chassis components known as Shop Replaceable Units (SRU).

SIZE	CODE IDENT NO.	DRAWING NO.	
A	80206	ICD-GPS-060	
SCALE	REV	A	SHEET
			16

The Receiver LRU's of the GPS Air Sets and Sea Sets will each be equipped with a common Precise Time and Time Interval (PTTI) SRU specifically designed to exchange time related information with other platform systems. A diagram showing the type of interfaces available in this SRU is shown in Figure 4.

**4.2 General Characteristics.** The PTTI I/O port shall be a two-way digital interface of precise time information. The interface will provide precise time synchronization between GPS users with Coordinated Universal Time (UTC). The port shall also receive external time aiding signals (from a cesium time standard, etc) when available. This information can be used by the UE to initialize its time accurately, and therefore, aid in the acquisition of the initial satellite constellation.

The UE shall be designed to receive any of the following input signals: one pulse per second synchronizing signal; a BCD message consisting of time of day (UTC), day of year, and Time Figure of Merit (TFOM) signal; and a timing fault discrete.

Although the year is not part of the BCD input string, the UE must know the year in order to initialize its time correctly. Therefore, if the year is not known by the UE, it must be input via an alternate source.

The UE shall provide the following output signals: one pulse per second synchronized with the UTC second rollover; one pulse per minute synchronized with the UTC minute rollover; a BCD time message consisting of time of day (UTC), day of year, and TFOM; a timing fault discrete; and a HAVE QUICK interface consisting of time of day, day of year, year and TFOM data. These outputs are generated by the UE only when the Time Figure of Merit is less than or equal to 7. Refer to Figure 11 for TFOM definition.

The PTTI SRU shall be designed to operate in conjunction with the UE Built In Test (BIT) circuitry. The BIT shall be designed to evaluate the health of the PTTI SRU and results may effect the status of the UE timing fault discrete.

SIZE	CODE IDENT NO.	DRAWING NO.
A	80206	ICD-GPS-060
SCALE	REV	SHEET
	A	17

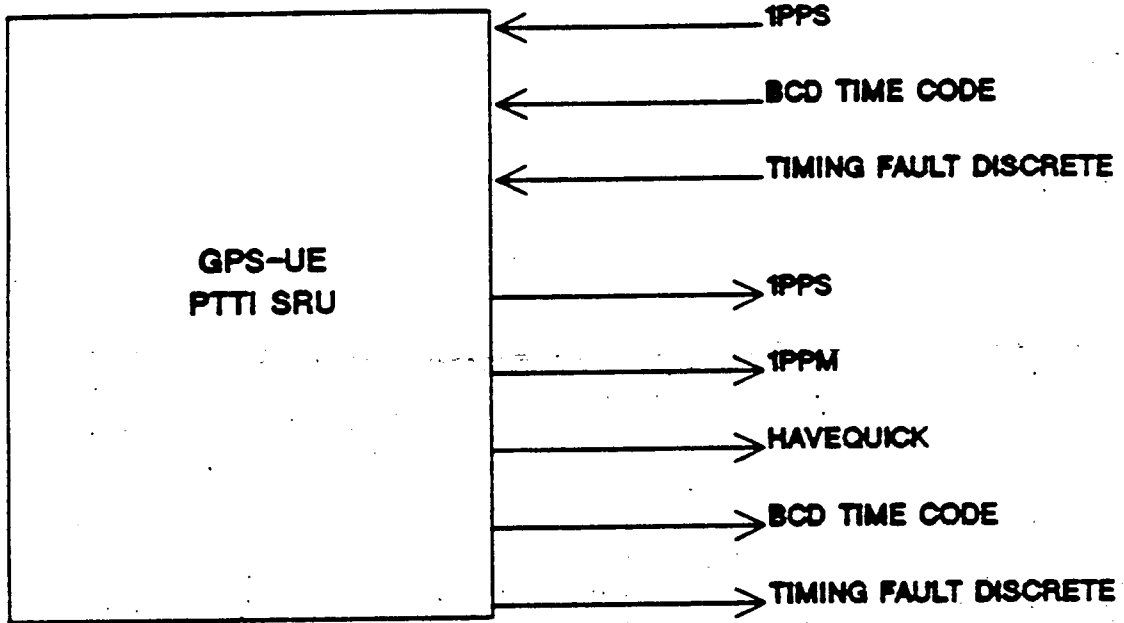

FIGURE 4. GPS-UE PTTI INTERFACES

SIZE	CODE IDENT NO.	DRAWING NO.
A	80206	ICD-GPS-060
SCALE	REV	SHEET
		18



4.3 Signal Inputs To PTTI Port.

4.3.1 Time Rollover Pulse (1 PPS).

4.3.1.1 Functional Description. The leading edge of this pulse indicates the occurrence of time rollover.

4.3.1.2 Signal Characteristics. The Time Rollover signal will be a one pulse per second (1 pps) signal, synchronized to an external source representing the UTC second rollover.

4.3.1.3 Electrical Characteristics. The electrical characteristics are shown in Figure 5. If required for testing purposes, the pulse width at the 50% level may be determined by extrapolation.

4.3.2 BCD Time Code.

4.3.2.1 Functional Description. The PTTI port shall receive a BCD code that shall be used in conjunction with the 1 PPS signal to identify the time of the current one second time rollover.

4.3.2.2 Signal Characteristics. The code shall be a forty (40) bit serial-8421 BCD code defining UTC time of day, day of year, and Time Figure of Merit (TFOM) transmitted at a 50 bps rate. Formats of the data are outlined in Figure 6. Bits 41 through 50 will be set at a mark (logical one). The first bit shall be the most significant bit of the hours. The 40th bit shall be the least significant bit of the TFOM. The data contained shall represent previous 1 pps rollover. The TFOM is defined in paragraph 4.6.

In the event that the source of the signal cannot provide TFOM, or TFOM and day of year, the signal shall be modified as indicated in paragraph 4.3.2.4.

4.3.2.3 Electrical Characteristics. A logical one state (mark) shall be denoted by a positive voltage, and a logical zero state (space) by a negative voltage. The voltages shall be 0.10 to 6.0 VDC and -0.10 to -6.0 VDC line to line, in accordance with MIL-STD-188-100 terminator requirements for a balanced low level digital interface.

SIZE	CODE IDENT NO.	DRAWING NO.	
A	80206	ICD-GPS-060	
SCALE	REV	SHEET	
	A	19	

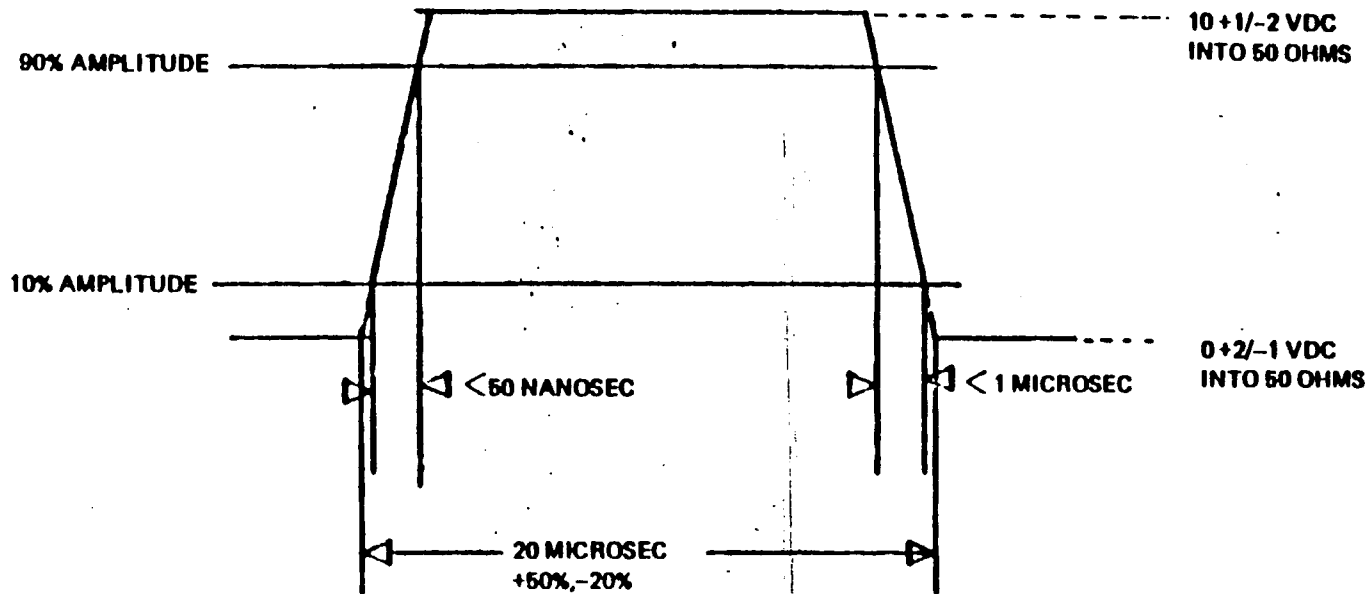

THE LEADING (POSITIVE GOING) EDGE OF THIS PULSE INDICATES ONE SECOND ROLLOVER.

FIGURE 5. INPUT TIME ROLLOVER PULSE (1 PPS) SIGNAL CHARACTERISTICS

SIZE	CODE	IDENT NO.	DRAWING NO.
A	80206		ICD-GPS-060
SCALE	REV		SHEET
			20

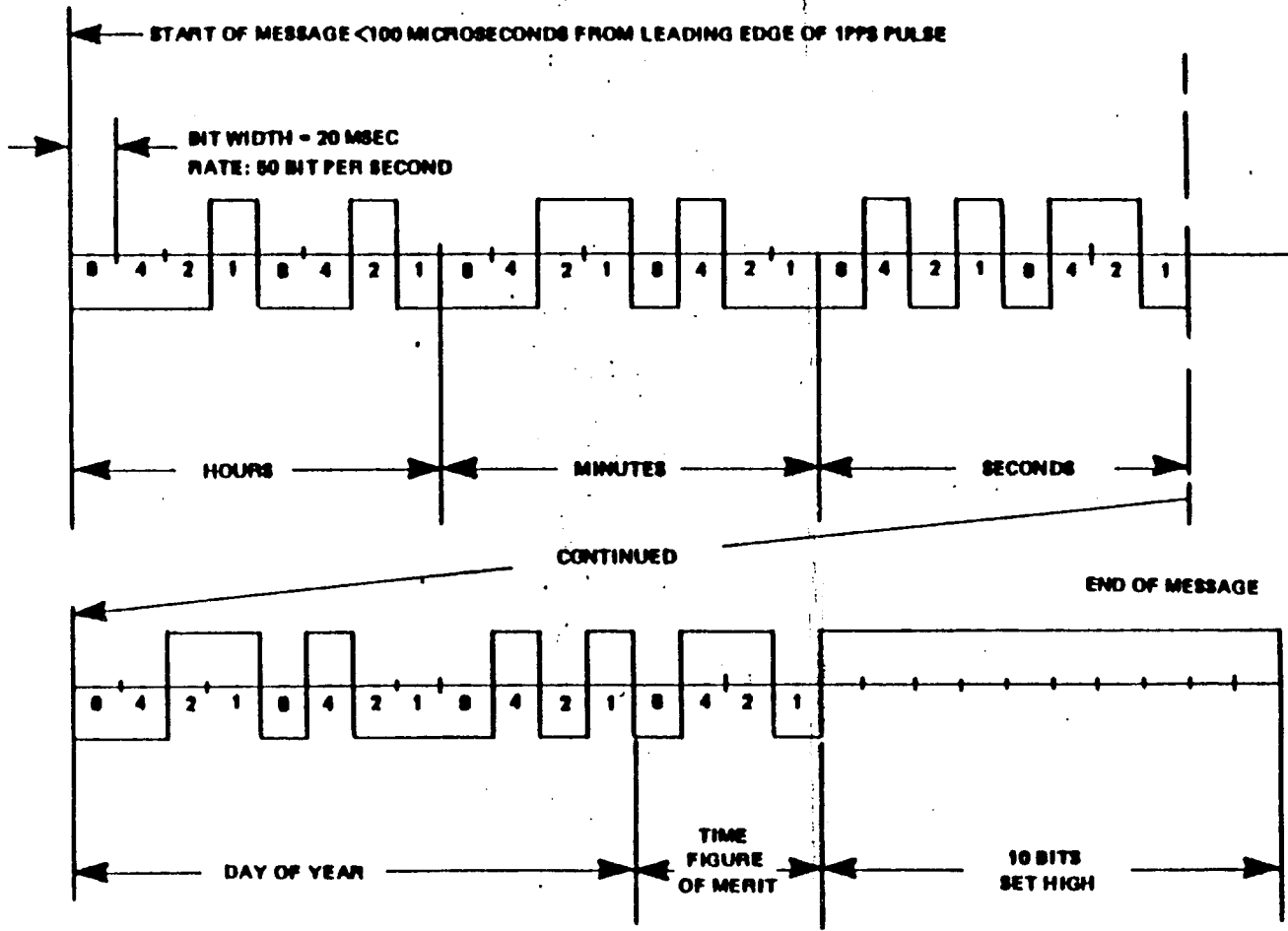

EXAMPLE SHOWN IS TIME 12:34:00  
 DAY 348  
 FOM 0

NOTE: SIGNALS IN ACCORDANCE WITH MIL-STD-188-100  
 BALANCED LOW LEVEL DIGITAL INTERFACE  
 REQUIREMENTS.

FIGURE 6. SIGNAL CHARACTERISTICS OF BCD TIME CODE

SCALE	A	SIZE CODE IDENT NO.	80206	DRAWING NO.	ICD-GPS-060
REV	A	SHEET	21		

4.3.2.4 Deviations from the 40 Bit Time Code. In the event that the external BCD signal does not include TFOM, or TFOM and day of year, the 8421 BCD slots for these parameters will be set at a mark (logical one state) by the interfacing equipment. The UE shall recognize these BCD data slots, when all set at a mark, to represent no data available. Under these conditions, the UE shall accept an alternate source of data for the day of year.

4.3.3 Timing Fault Discrete.

4.3.3.1 Functional Description. The interfacing equipment which supplies the 1 pps and BCD data shall provide a timing fault discrete which will inform the UE if the transmitting equipment is functioning properly.

In the event that the BCD time code information is provided to the GPS UE receiver without a Timing Fault Discrete signal (hard wire), the UE receiver shall recognize this condition and assume the Timing Fault Discrete signal line to be set high, thus accepting any data that shall be input to the GPS receiver via the PTTI port.

4.3.3.2 Signal Characteristics. The signal shall be a voltage level in a logical one or zero state. A logical one state indicates normal operation and valid time information. A logical zero state indicates a fault within the external equipment and implies that the UE shall not use the data.

4.3.3.3 Electrical Characteristics. A logical one state is defined as +3 to +5.5 Volts dc (Vdc). A logical zero state is defined as 0 Vdc to +0.5 Vdc, when loaded with a UE input circuit of 5000 ohms connected to +5Vdc (standard transistor logic load).

4.3.4 Configuration Inputs. The UE Receiver shall provide configuration inputs defining Host Vehicle utilization of various PTTI interface functions. Details of these configuration inputs shall be defined in the applicable receiver specification: CI-RCVR-3010 or CI-RCVR-3011.

4.4 Signal Outputs from the PTTI Port.

4.4.1 Time Rollover Pulse (1 PPS).

4.4.1.1 Functional Description. The leading edge of this pulse indicates the occurrence of time rollover.

SIZE	CODE IDENT NO.	DRAWING NO.
A	80206	ICD-GPS-060
SCALE	REV	SHEET
	A	22

4.4.1.2 Signal Characteristics. The Time Rollover signal shall be a one pulse per second (1 pps) signal synchronized to the UTC second rollover.

4.4.1.3 Electrical Characteristics. The electrical characteristics are shown in Figure 7. If required for testing purposes, the pulse width at the 50% level may be determined by extrapolation.

4.4.2 Time Synchronizing Signal (1 PPM).

4.4.2.1 Functional Description. The leading edge of this pulse indicates the occurrence of time rollover.

4.4.2.2 Signal Characteristics. The Time Synchronizing Signal shall be a one pulse per minute (1 ppm) signal synchronized to the UTC minute rollover.

4.4.2.3 Electrical Characteristics. The electrical characteristics are shown in Figure 7. If required for testing purposes, the pulse width at the 50% level may be determined by extrapolation.

4.4.3 BCD Time Code.

4.4.3.1 Functional Description. The PTTI port shall output a BCD code which shall be used by the interfacing equipment in conjunction with the 1 PPS signal to identify current one second time rollover.

4.4.3.2 Signal Characteristics. The code shall be a forty (40) bit serial 8421 BCD code, defining UTC time of day, day of year, and Time Figure of Merit (TFOM), transmitted at a 50 bps rate. The data contained shall represent previous 1 pps rollover. Formats of the data are outlined in figure 6. Bits 41 through 50 will be set at a mark (logical one).

The first bit shall be the most significant bit of the hour. The 40th bit shall be the least significant bit of the TFOM. The TFOM is defined in paragraph 4.6.

4.4.3.3 Electrical Characteristics. A logical one state (mark) shall be denoted by a positive voltage and a logical 0 state (space) by a negative voltage. The voltages shall be +0.8 to +6.0 VDC and -0.8 to -6.0 VDC line to line. The signal shall be in accordance with MIL-STD-188-100 driver requirements for a balanced low level digital interface. Wave shaping shall not be performed

SIZE	CODE IDENT NO.	DRAWING NO.
A	80206	ICD-GPS-060
SCALE	REV	SHEET
	A	23

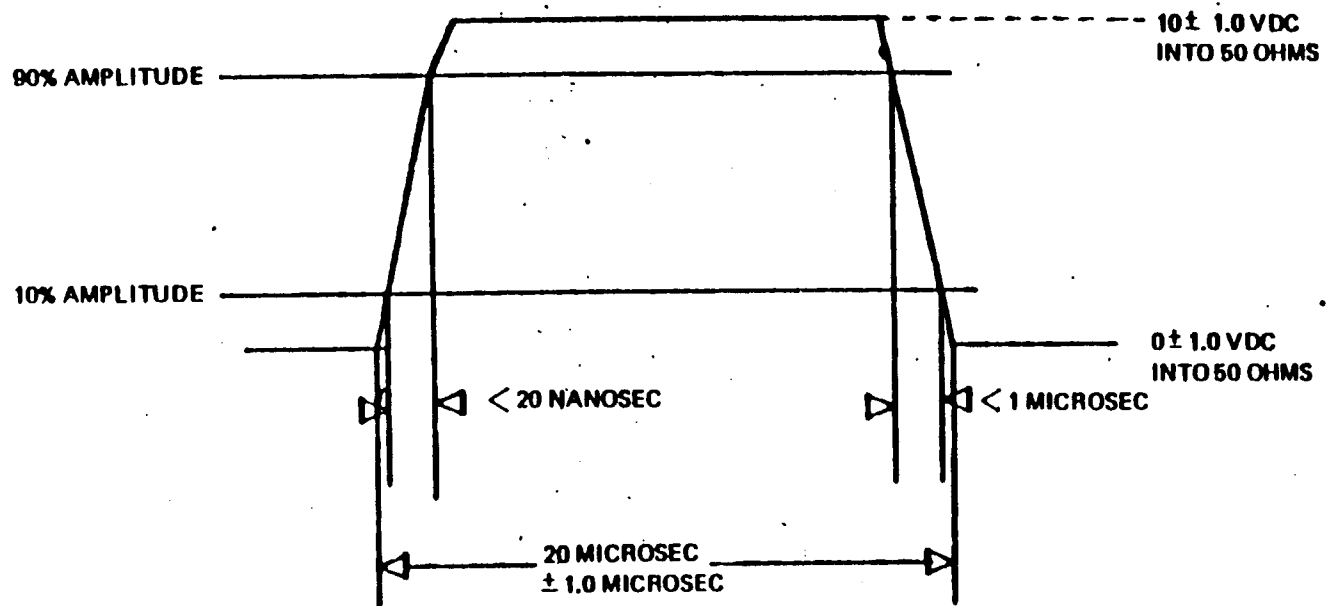

THE LEADING (POSITIVE GOING) EDGE OF THIS PULSE INDICATES ONE SECOND ROLLOVER.

FIGURE 7. OUTPUT TIME ROLLOVER PULSE (1 PPS) AND TIME SYNCHRONIZING SIGNAL (1 PPM) SIGNAL CHARACTERISTICS

SCALE	A	SIZE CODE IDENT. NO.	DRAWING NO.
REV	80206	ICD-GPS-060	
SHEET			
	24		

↓

#### 4.4.4 Timing Fault Discrete.

4.4.4.1 Functional Description. The GPS UE shall provide a timing fault discrete signal which will inform the external equipment whether or not the UE 1PPS, 1PPM, BCD and HAVE QUICK data is valid. The interface output signals are considered invalid if one or more of the following conditions exist:

1. The UE internal clock has malfunctioned.
2. The UE built-in test has determined a PTTI SRU malfunction exists in one or more of the functions being used by the host vehicle.
3. The UE is performing its power-on circuitry testing.
4. The UE has been commanded to TEST mode and is performing the built-in-test function.

4.4.4.2 Signal Characteristics. The signal shall be a voltage level in logical one or zero state. A logical one state indicates no PTTI SRU malfunctions. A logical zero state indicates one or more of the above conditions described in section 4.4.4.1 exists.

4.4.4.3 Electrical Characteristics. A logical one state is defined as +3 to +5.5 volts dc (Vdc), and a logical zero state is defined as 0 Vdc to +0.5 Vdc, when loaded with 5000-ohms connected to +5 Vdc (standard transistor logic load).

#### 4.4.5 HAVE QUICK Interface.

4.4.5.1 Functional Description. The PTTI port shall output a signal in HAVE QUICK format.

4.4.5.2 Signal Characteristics. The HAVE QUICK signal employs biphase (Manchester II) transmission at approximately 1667 bits per second. A one is defined as 300 microseconds of a high state followed by 300 microseconds of a low state. A zero is defined as 300 microseconds of a low state followed by 300 microseconds of a high state. A transmission of 240 milliseconds of logical ones (400 bits) precedes the start of message indicator (16 bits) and time, day of year, year and TFOM message (96 bits). The message and relative timing is shown in Figure 8. The interpretation of TFOM is provided in paragraph 4.6.

SIZE	CODE IDENT NO.	DRAWING NO.	
A	80206	ICD-GPS-060	
SCALE	REV	A	SHEET
			25

↑

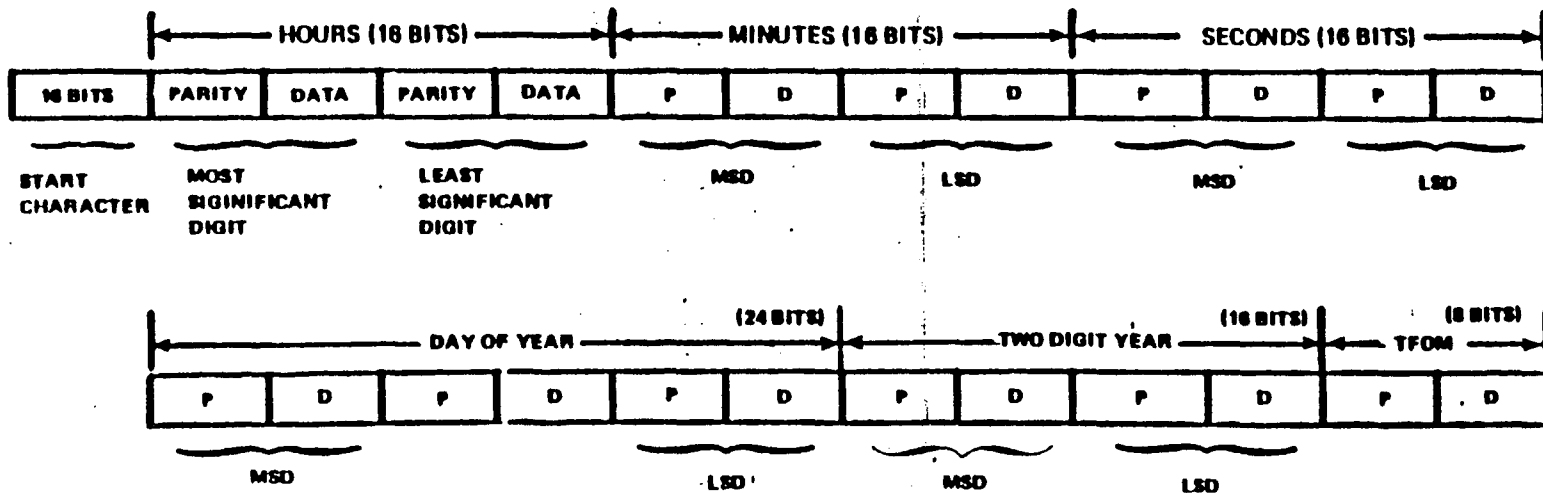
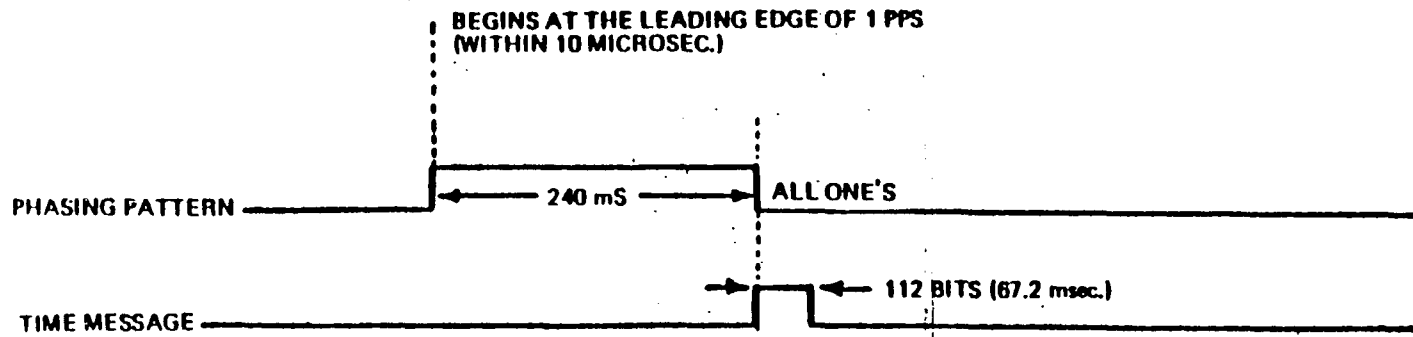

FIGURE 8. HAVE QUICK TOD OUTPUT FORMAT AND TIMING



The transmission is initiated on a time mark, so that the first bit of the 400 "ones" starts within 10 microseconds of the leading edge of the 1PPS. The interfacing equipment detects the preamble of 400 "logical ones" and aligns itself to the bit boundaries through a phase-lock loop.

The start of message indicator that follows the "ones" verifies that the time, day of year, year and TFOM message will follow. Each 8 bit character in the data message (time of day, day of year, year and TFOM) is defined by a modified 8:4 Hamming Code. See paragraphs 4.4.5.4 and 4.4.5.5 for the message format and an explanation of the Hamming Code respectively. The two start of message characters (8 bits each) are not in the modified Hamming Code.

4.4.5.3 Electrical Characteristics. A logical high state is defined as +4.5 to +5.5 volts and a logical low state is defined as 0 to +0.5 volts. It will source and sink 0.5 milliamperes. The total data period of a single bit of information is 600 plus or minus 10-microseconds.

4.4.5.4 Message Format. The data message (time of day, day of year, year and TFOM) uses 8 bit characters in the format shown in Figures 8 and 9.

Every character, except the 16 bit "start of message indicator" follows the modified 8:4 Hamming Code described in paragraph 4.4.5.5.

4.4.5.5 Modified Hamming Code. The HAVE QUICK data message uses a modified Hamming Code employing 4 parity bits and 4 data bits for each 8 bit character. The specific character codes are summarized in Figure 10. The code enables the receiving equipment to detect and correct a single bit error in any character using the relationships in figure 10.

4.5. Short Circuit Protection. All PTTI outputs shall be protected from damage due to short circuits at any of the terminals. There shall be no degradation below the specified performance limits of any pulse output by short circuit of any other pulse output.

4.6 Time Figure of Merit. The Time Figure of Merit (TFOM) denotes the quality of the time solution as a discrete integer from 0-9. Figure 11 provides definition of TFOM which applies to both the GPS UE inputs and outputs.

SIZE	CODE IDENT NO.	DRAWING NO.
A	80206	ICD-GPS-060
SCALE	REV	SHEET
	A	27

<u>Character</u>	<u>Purpose</u>	<u>Contents</u>	<u>Notes</u>
1	Start of message	00010001	Start Characters with low probability of partial correlation
2	Indicator	11101001	
3	Hours, MS digit	4 parity, 4 data bits	8, 4, 2, 1, BCD
4	Hours, LS digit	4 parity, 4 data bits	8, 4, 2, 1, BCD
5	Minutes, MS digit	4 parity, 4 data bits	8, 4, 2, 1, BCD
6	Minutes, LS digit	4 parity, 4 data bits	8, 4, 2, 1, BCD
7	Seconds, MS digit	4 parity, 4 data bits	8, 4, 2, 1, BCD
8	Seconds, LS digit	4 parity, 4 data bits	8, 4, 2, 1, BCD
9	Day of Year, MS digit	4 parity, 4 data bits	8, 4, 2, 1, BCD
10	Day of Year, Middle Digit	4 parity, 4 data bits	8, 4, 2, 1, BCD
11	Day of Year, LS Digit	4 parity, 4 data bits	8, 4, 2, 1, BCD
12	Two Digit Year, MS digit	4 parity, 4 data bits	8, 4, 2, 1, BCD
13	Two Digit Year, LS digit	4 parity, 4 data bits	8, 4, 2, 1, BCD
14	Time Figure of Merit	4 parity, 4 data bits	8, 4, 2, 1, BCD*

Character code for characters 3 through 14 are in accordance with Figure 10  
 \*Time Figure of Merit is defined in paragraph 4.6

FIGURE 9. HAVE QUICK MESSAGE FORMAT

SIZE	CODE IDENT NO.	DRAWING NO.	
A	80206	ICD-GPS-060	
SCALE	REV	SHEET	28
	A		

<u>Character</u>	<u>Transmitted Code</u>							
	<u>Parity bit</u> P1, P2, P3, P4				<u>BCD data</u> D1, D2, D3, D4			
0	0	0	0	0	0	0	0	0
1	1	1	1	0	0	0	0	1
2	0	1	1	1	0	0	1	0
3	1	0	0	1	0	0	1	1
4	1	0	1	1	0	1	0	0
5	0	1	0	1	0	1	0	1
6	1	1	0	0	0	1	1	0
7	0	0	1	0	0	1	1	1
8	1	1	0	1	1	0	0	0
9	0	0	1	1	1	0	0	1

FIGURE 10. MODIFIED HAMMING CODE

The following bit groups have even parity (i.e. the the exclusive or of the bits in each group equals zero):

P1, D1, D2, D4

P2, D1, D3, D4

P3, D2, D3, D4

P1, P2, P3, P4, D1, D2, D3, D4

These character codes also enable the receiving equipment to detect, but not correct, two erroneous bits in any character.

SIZE	CODE IDENT NO.	DRAWING NO.
A	80206	ICD-GPS-060
SCALE	REV	SHEET
	A	29

<u>Integer</u>	<u>Estimated Accuracy (with respect to UTC)</u>
All bits high	No information
9	Greater than 10 milliseconds (ms) or fault
8	1-10 ms
7	100 microseconds (us) - 1 ms
6	10 us - 100 us
5	1 us - 10 us
4	100 nanoseconds (ns) - 1 us
3	10 ns - 100 ns
2	1 ns - 10 ns
1	better than 1 ns
0	Proper/nominal operation (used when external equipment cannot compute actual TFOM).

FIGURE 11. TIME FIGURE OF MERIT DEFINITION

SIZE	CODE IDENT NO.	DRAWING NO.
A	80206	ICD-GPS-060
SCALE	REV	SHEET
	A	30

4.7 Control and Display PTTI Functions.

4.7.1 Functional Description. In general, the GPS Control Display Unit (CDU) provides the operator with the capability to control the UE input data and observe UE generated outputs. The GPS CDU contains operating controls, a data entry keyboard, and alpha numeric displays. The CDU has been developed to include the following performance characteristics.

The UE shall use time of day, and day of year data from an external time standard, unless overridden by an operator entry. If the external time standard cannot provide day of year, then the UE shall be capable of accepting the day of year from an alternate source.

The CDU shall display PTTI Time Figure of Merit based on navigation mode, receiver operating status, navigation algorithm statistics and equipment status. (see section 4.6).

The CDU shall display the time difference between communicating external time standard and UTC.

4.7.2 Time Standard Error Display.

4.7.2.1 Functional Description. To aid synchronization of the time standard, a GPS display of time standard error shall be provided to the operator to indicate that a time reset may be needed.

4.7.2.2 Display Characteristics. A GPS display of the time difference between the external standard BCD and 1 pps input and GPS estimate of UTC (external source minus GPS UTC) shall be provided as a signed decimal number with a range of +9.999 seconds and a resolution of one nanosecond.

4.8 Safety. The GPS PTTI port shall be designed to satisfy the safety requirements of MIL-STD-454 and safety requirements outlined in the applicable Generic Interface Control Documents and System Specifications.

SIZE	CODE IDENT NO.	DRAWING NO.
A	80206	ICD-GPS-060
SCALE	REV	SHEET
	A	31/32

**Appendix A**

**This appendix contains no requirements and is for  
informational purposes only**

SIZE	CODE IDENT NO.	DRAWING NO.
<b>A</b>	<b>80206</b>	<b>ICD-GPS-060</b>
SCALE	REV	SHEET
	<b>A</b>	<b>A-1/2</b>

↓

**A1.0 PTTI Applications.** The various data signals available to and from the PTTI SRU may be used in combination with each other or, in combination with other UE data exchange ports, to satisfy particular platform PTTI requirements. Some examples are described below.

**A1.1 Use with UE 1553A/B I/O Port.** The 1 PPS Pulse and 1553 I/O Port available on the Air Set may be used in combination to exchange precise time information between the UE and the platform system (Figure A-1). The 1 PPS Pulse will mark the precise time of occurrence of the one second roll-over and the 1553 bus is used to describe that time in a message transfer following the one second pulse. The time information shall be in 8421 BCD code, containing time of day, day of year, and Time Figure of Merit (TFOM) information, respectively.

In this way, precise time information may be transferred in either direction between the two systems. Reference ICD-GPS-059, NAVSTAR GPS Phase III Interface Control Document, GPS-User Equipment-MIL-STD-1553 Multiplex Bus Interface for further details.

**A1.2 Use with Cesium Standard.** The 1 PPS Pulse, BCD and Timing Fault Discrete signal may be used in conjunction with compatible Cesium Standards to exchange Precise Time and Time Interval in either direction (Figure A-2). The usual application is calibration of the Cesium Standard or use of the Standard by the UE as an external time reference prior to satellite acquisition period. The BCD message defines the time and TFOM represented by the 1 second pulse at the start of the message.

**A1.3 Use with Frequency Standard.** Many frequency standards, such as the Navy AN/URQ-23, can utilize the UE 1 PPS or 1 PPM PTTI output for on-board calibration (Figure A-3). Ordinarily these devices must be removed from the platform during calibration.

**A1.4 Use with Frequency Hopping Radio Systems.** Radio sets, employing frequency hopping techniques, require a precise time reference for proper reception. The UE HAVE QUICK interface is entirely compatible with receivers currently employing transit receivers as precise time reference. AN/ARC-182 and AN/WSC-3 are examples of frequency hopping receivers (Figure A-4).

SIZE	CODE IDENT NO.	DRAWING NO.
A	80206	ICD-GPS-060
SCALE	REV	SHEET
	A	A-3

↑

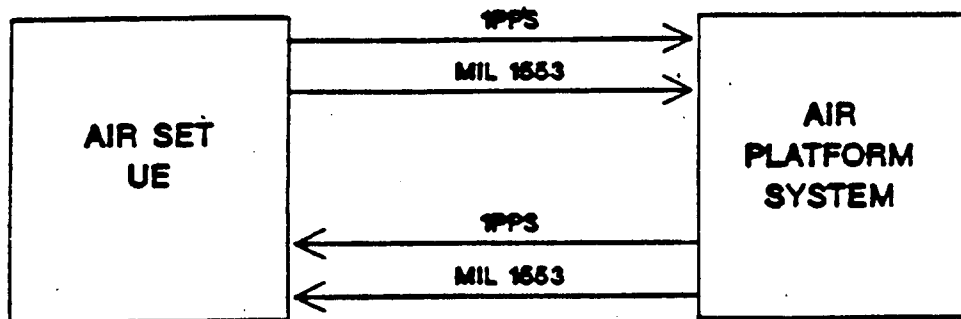

FIGURE A-1. USE OF PTTI SRU AND MIL-1553 INTERFACE TO TRANSMIT PRECISE TIME

SIZE	CODE IDENT NO.	DRAWING NO.
A	80206	ICD-GPS-060
SCALE	REV	SHEET
	A	A-4



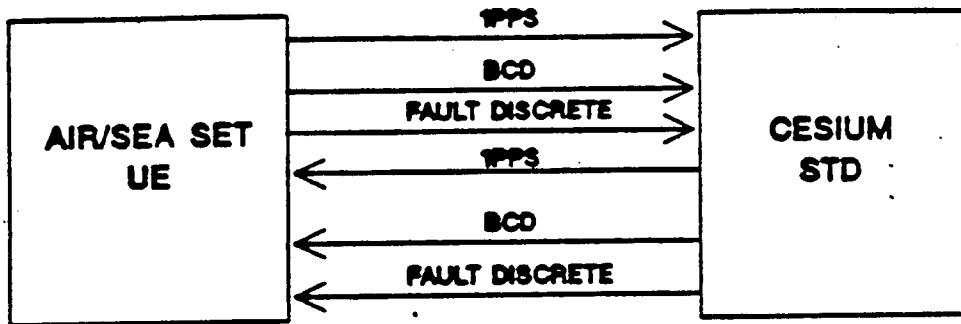

FIGURE A-2. GPS-UE (AIR OR SEA SET) PTTI INTERFACE WITH EXTERNAL CESIUM STANDARDS

SIZE	CODE IDENT NO.	DRAWING NO.
A	80206	ICD-GPS-060
SCALE	REV	SHEET
	A	A-5

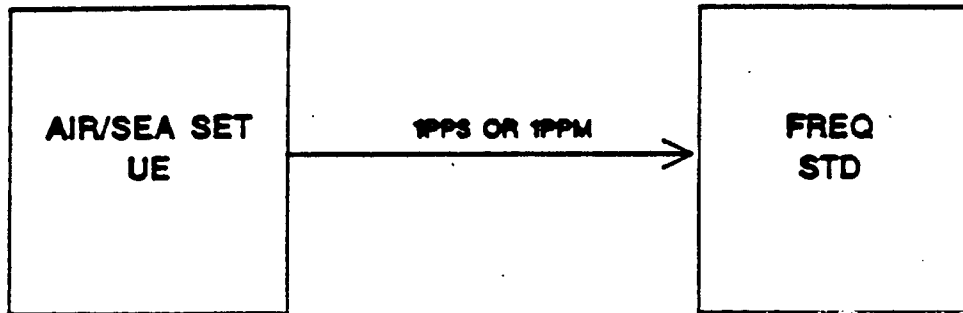

FIGURE A-3. GPS-UE (AIR OR SEA SET) PTTI INTERFACE WITH EXTERNAL FREQUENCY STANDARDS

SIZE	CODE IDENT NO.	DRAWING NO.	
A	80206	ICD-GPS-060	
SCALE	REV	A	SHEET
			A-6



FIGURE A-4. GPS-UE (AIR OR SEA SET) HAVE QUICK APPLICATIONS

SIZE	CODE IDENT NO.	DRAWING NO.	
A	80206	ICD-GPS-060	
SCALE	REV	SHEET	
	A	A-7/8	